

PUMP SERIES 999

User and Maintenance Manual

Warranty information

TABLE OF CONTENTS

1. INTRODUCTION
2. GENERAL DESCRIPTION
3. PRODUCT-MACHINE IDENTIFICATION
4. TECHNICAL SPECIFICATIONS
5. MACHINE COMPONENTS
6. UNPACKING AND INSTALLING THE MACHINE
7. INSTRUCTIONS FOR USE
8. TROUBLESHOOTING
9. MAINTENANCE PROCEDURE
10. DISPOSAL
11. ORDERING INFORMATION
12. DIMENSIONS
13. HANDLING AND TRANSPORTATION
14. OPERATING HAZARDS
15. PRECAUTIONS
16. WARRANTY INFORMATION
17. DECLARATION OF COMPLIANCE WITH STANDARDS
18. DROPSA LOCATIONS



1. INTRODUCTION

This user's and maintenance manual refers to a **series 999 modular motor-driven gear pump** for oil and grease. This modular pump is particularly suitable for the distribution of oil and grease in lubrication systems.

It is recommended that this manual is carefully kept in good condition and is always available to persons requiring to consult it.

To request further copies, updates or clarifications with respect to this manual contact the Engineering Department at Dropsa SpA.

The use of the pump referred to in this manual must be entrusted to qualified personnel with a knowledge of hydraulics and electrical systems.

The manufacturer reserves the right to update the product and/or the user's manual without the obligation to revise previous versions. It is however, possible to contact the Engineering Department for the latest revision in use.

The pump, and any accessories mounted on it, should be carefully checked immediately on receipt and in the event of any discrepancy or complaint the Dropsa SpA Sales Department should be contacted without delay.

DROPSA S.p.A. declines to accept any responsibility for injuries to persons or damage to property in the event of the non-observance of the information presented in this manual.

Any modification to component parts of the system or the different destination of use of this system or its parts without prior written authorisation from DROPSA S.p.A. will absolve the latter from any responsibility for injury or damage to persons and/or property and will release them from all obligations arising from the guarantee.

Instructions for the correct ordering of the required model, and a list of importers, is shown in Section 4.

2. GENERAL DESCRIPTION

The features which distinguish this pump are:

- ✓ **high performance;**
- ✓ **simplicity of construction;**
- ✓ **modularity.**

The simplicity of construction guarantees long life, reliability and simplified and reduced maintenance. The modularity of the components allows the system engineer to construct the lubrication unit to meet the specific needs of the lubrication system it is serving.

3. PRODUCT-MACHINE IDENTIFICATION

Machine identification yellow label is located on the front side of the reservoir and contains product serial number, input voltage and details of the operating parameters.

4. TECHNICAL SPECIFICATIONS

4.1 Electrical system

Piston pump

AC ELECTRIC MOTOR	
Electrical power supply	Single phase 220 VAC 50 H2 0.12 KW 3-Phase 220/380 VAC 50 H2 0.18 KW 4 pole

DC ELECTRIC MOTOR	
Electrical power supply	Single phase 24 VDC – 120 W 12 VDC – 100 W

4.2 Hydraulic system

Connection between the pump and the valve block by steel tubing with connectors. (Only for requested versions)

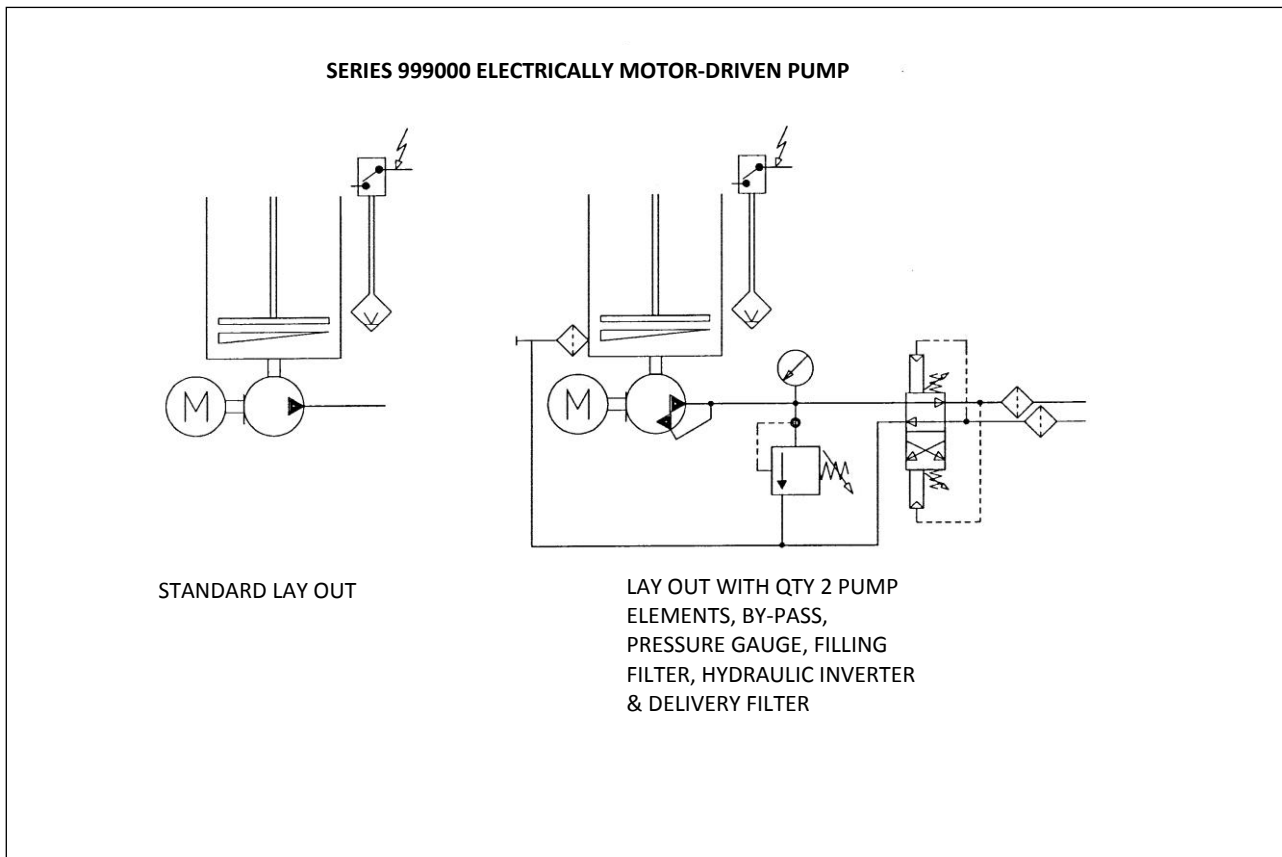

4.3 Other data

Class of protection	F
Grade of mechanical protection	IP 55
Operating temperature	- 5 - + 40 °C
Operating humidity	90 % relative humidity
Preservation temperature	- 20 - + 50 °C
Level of continuous sound pressure	< 70 dB(A)

5. MACHINE COMPONENTS

The pump is made up of a series of components:

CHARACTERISTICS	PUMP 999 Electric piston pump
Fixed flow rate pump element Piston diam. 6 mm. Piston diam. 8 mm.	0.20 cc/stroke 0.35 cc/stroke
Variable flow rate pump element Piston diam. 6 mm: Piston diam. 8 mm.	from 0.028 to 0.20 cc/stroke from 0.05 to 0.35 cc/stroke
Maximum pressure - bar (MPa)	*450 (45)
Tank capacity	3 – 5 – 10 - 30
Characteristics of the mineral lubricant	oil: min. 15 CSt grease: max. NLGI 2
Temperature of use For operations outside of this range	- 5C - + 40 °C Consult Engineering Dept Dropsa
Variable flow rate model: AC Motor (specify if single or 3 phase) DC Motor Fixed flow rate model: AC Motor (specify if single or 3 phase) DC Motor	220-380 V 50/60 Hz at 1500 rpm 24V at 2200 rpm 220-380 V 50/60 Hz at 1500 rpm 24V at 2200 rpm
Insulation	Class F



*Value refers to pumps with 8.5 cm³ / min capacities

5.1 Minimum level indicator

Electro-mechanical type

- Normally closed at minimum level;
- maximum commutable power ISA;
- maximum commutable voltage 220/250 VAC.

Lubricant maximum level and reserve indicator is available on request: fitted with floats and two switches (minimum and zero)

5.2 Pressure gauge (Accessory)

Two types of pressure gauge are available:

PART N°	PRESSURE RANGE
299196 291395	0 ÷ 500 bar (0 ÷ 50 MPa)

5.3 Pressure regulator (Accessory)

Three types of regulator (valves) are available to protect the system from overpressures.

PART N°	PRESSURE RANGE
299450	0 ÷ 250 bar (0.25 MPa)
299451	0 ÷ 350 bar (0.35 MPa)
299452	50 ÷ 450 bar (5.80 MPa)



WARNING: Pay strict attention to what is indicated on the valves when assembling. Incorrect assembly of the regulator (valve) can result in an overpressure which could prejudice the correct functioning of the pump itself and be dangerous for the user.

5.4 Filling filter (only for the grease version) (Accessory)

This removable cartridge filter is recommended to ensure the filling of lubricant which is free from foreign bodies and to avoid the formation of air bubbles.

5.5 Hydraulic inverter (Accessory)

PART N°	DESCRIPTION
86240	Complete with base mounting plate
86199	Inverter only

Pressure up to 300 bar.

Type of lubricant: oil minimum viscosity 15 cSt – grease maximum consistency NLGI2

5.6 Auxiliary pump element

The pumps are supplied with one pump element only, but a second one can be mounted; this would permit the feeding of two lines independently or the combining of the outlets of the two pump elements to obtain a doubling of the flow rate.

To obtain the part number of the auxiliary pump element consult the table by utilising the last number off the 999 base pump, or its flow rate specification (at 1500 rpm) and its maximum working pressure.

5.7 Maximum level electrical contact

The metal tanks, except those of 3 and 5 litres, can be fitted with electrical maximum level indicators for automatic replenishing of the tank.

PART N°	MAXIMUM LEVEL ELECTRICAL CONTACT
299197	Tanks for grease
291155	Tanks for oil

6. UNPACKING AND INSTALLING THE PUMP

6.1 Unpacking

Once a suitable location has been found to install the unit remove the pump from the packaging. Check the pump has not been damaged during transportation or storage. No particular disposal procedures are necessary, however packing should be disposed of in accordance with regulations that may be in force in your area or state.

6.2 Installing the pump

Damage to the power supply cable and housing could result in contact with high voltage (220/380 VAC) live parts and hence be a danger to life:

- ◆ carefully check the integrity of the power supply cable and the unit before use;
- ◆ In the event of there being damage to the power supply cable or the unit, **DO NOT** put the system into service!;
- ◆ Replace the damaged power supply cable with a new one;
- ◆ The unit can be opened and repaired **ONLY** by qualified personnel;
- ◆ In order to prevent dangers of electric shock due to direct or indirect contact with live parts it is necessary that the electrical power supply line is adequately protected by a suitable differential magneto-thermal circuit breaker with an intervention threshold of 0.03 Ampere and a max. operating time of 1 millisecond.



The breaking capacity of the circuit breaker must be = 10 kV and the nominal current $I_n = 4$ A.

- ◆ The connection of the pressure switch mounted directly on the tank must be 24 VAC/DC.
- ◆ The pump **MUST NOT** be submersed in fluids or utilised in environments which are particularly aggressive or explosive/inflammable if not prepared for this purpose beforehand by the supplier.
- ◆ For correct fixing verify the distance between centres shown in the diagram in Section 2.
- ◆ Use gloves and safety glasses as required in the lubrication oil safety chart;

- ◆ **DO NOT** use aggressive lubricants with NBR gaskets and seals; if in doubt consult the Engineering Department of Dropsa SpA, who will provide a chart with the details of recommended oils;
- ◆ **DO NOT** ignore dangers to health and observe all hygiene standards;
- ◆ **WARNING!** All electrical components must be grounded. This refers to both electrical components and control devices. In this regard ensure that the ground cable is correctly connected. For reasons of safety the ground cable must be approx. 100 mm longer than the phase cables. In the event of accidental detachment of the cable, the ground terminal must be the last to be removed.

Action to be taken prior to start up:

- ◆ Verify the integrity of the pump;
- ◆ Fill the tank with suitable lubricant (min/max indication on the tank);
- ◆ Verify that the pump is at operating temperature and the tubing free from air bubbles;
- ◆ Check that the electrical connections have been effected correctly (UNI 64/8, IEC ...).

The minimum level indicator is supplied, unless otherwise specified by the customer, with the contact closed for minimum level. Should the user require to use a normally open contact it will be necessary to invert the operating direction of the microswitch.

7. INSTRUCTIONS FOR USE

1. Verify the settings made;
2. Press the start button of the machine to which the 999 series pump is connected;
3. Verify the starting of the pump;
4. Verify the adequate lubrication of the machine (if doubt exists as to the correct functioning consult the Engineering Department of Dropsa SpA to request test procedures).

8. TROUBLESHOOTING

DIAGNOSTIC TABLE

ANOMALY	CAUSE	REMEDY												
<p>The pump does not deliver lubricant</p>	<p>The tank is empty</p> <p>The tank has been filled from above and not through the side connection fitted with a filter.</p> <p>The piston of the pump element assembly is seized or the piston return spring is broken</p> <p>The pump does not function because the grease being used is of a consistency greater than NLGI 3 (max. recommended consistency).</p> <p>The pump fails to function because it has been run with the tank empty creating an air lock inside the pump itself.</p>	<p>→ Refill the tank with clean lubricant, in accordance with the procedure shown in the Maintenance section. Warning: if the tank has emptied without the minimum level electrical contact having signalled the minimum level, check the contact.</p> <p>→ Remove the air vent plug B (see fig. on page 6) and run the pump allowing the grease to exit until free from air bubbles. Replace and partly screw in plug B and continue running the pump until grease exits between the threads and the plug and then fully tighten the vent plug.</p> <p>→ Replace the pump element.</p> <p>→ Remove the tank from the pump, remove the unsuitable grease and wash out the tank and filter with petrol. Disassemble the pump element and wash out with petrol. Reassemble completely, refill the tank (utilising the side connection fitted with a filter) with suitable grease and run the pump, ensuring that grease free from air bubbles exits. If necessary, remove the air vent plug B (see fig. on page 6) and proceed as in the previous point.</p> <p>→ Remove the plug which closes the auxiliary pump element outlet or, where the pump has two elements fitted, remove one of the two pump elements and run the pump until homogeneous grease exits. Replace the plug (or the pump element) and continue running the pump until grease exits free from air bubbles. If necessary, remove the air vent plug B (see fig. on page 6) and proceed as indicated above.</p>												
<p>Irregular pressure</p>	<p>Pump element return valve and seating dirty.</p> <p>Pressure regulating valve (by-pass) dirty.</p>	<p>→ Disassemble the parts shown in diagram A (see fig. on page 6) and wash them in petrol. Also clean the valve seating. Check the condition of the components and replace if necessary.</p> <p>→ Disassemble the parts of the valve shown in the diagram and wash them in petrol. Also clean the valve seating. Check the condition of the components and replace if necessary.</p> <table border="0" data-bbox="671 1727 1284 1854"> <tr> <td>Valve Part N°</td> <td>Spring part N°</td> <td>Pressure reg.</td> </tr> <tr> <td>299450</td> <td>299456</td> <td>0 - 250 Bar</td> </tr> <tr> <td>299451</td> <td>299457</td> <td>0 - 350 Bar</td> </tr> <tr> <td>299452</td> <td>299458</td> <td>0 - 450 Bar</td> </tr> </table> <p>Before reassembling the valve, check that the ring seal 18818 has not been damaged.</p>	Valve Part N°	Spring part N°	Pressure reg.	299450	299456	0 - 250 Bar	299451	299457	0 - 350 Bar	299452	299458	0 - 450 Bar
Valve Part N°	Spring part N°	Pressure reg.												
299450	299456	0 - 250 Bar												
299451	299457	0 - 350 Bar												
299452	299458	0 - 450 Bar												

ANOMALY	CAUSE	REMEDY
Irregular flow rate	Screw C, which secures the pump element D and return spring E, is loose.	Remove the pump element assembly from the pump body and completely disassemble it. To reassemble the pump element assembly see the sequence in the diagram. Check all the parts and reassemble after having washed them all in petrol. Warning: put some Loctite type sealant on screw C, which is inserted into pump element D. Hold the pump element between wooden vice clamps to prevent damage to the lapped surface.

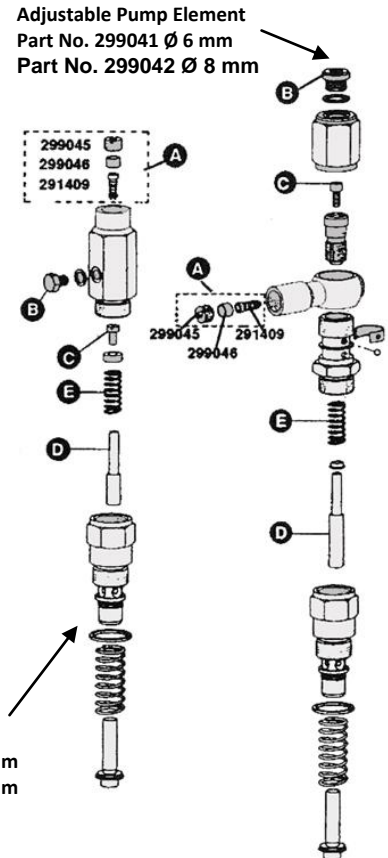

9. MAINTENANCE PROCEDURE



Locate the machine in conditions which facilitate easy access.
Utilise individual protection to avoid contact with mineral oil.

Periodic inspections

Periodically it is necessary to check:

VERIFICATION	WORK CYCLE/RUNNING TIME
The state of lubrication	1000/every 6 months
The oil/grease level	2000/once a year
Cleanliness of the filling and intake filter (where fitted)	500/every 6 months

The machine does not require any special tools to carry out checks or maintenance tasks. However, it is recommended that only tools suitable for the tasks and in good condition should be utilised to avoid injury to persons or damage to machine parts.

9.1 Assembly/Disassembly

No pump assembly operations are envisaged.

For wall mounting ensure adequate space is available (as shown in the installation diagram) to avoid abnormal postures and possible impacts; four fixing holes are provided for wall mounting and three for base fitting.

Subsequently it will be necessary, as previously described, to connect the pump to the machine hydraulically and then to connect the control panel.

During the disassembly phase ensure the tank is empty.

Disconnect the electrical and hydraulic parts.

Where the machine is to be scrapped, do not dispose of potentially polluting parts in the environment, following local regulations for their correct disposal.

At the time of the machine being scrapped it is necessary to remove and destroy the identification plate and all other relative documents.

9.2 Regulation

Flow rate (for versions with adjustable flow rates)

It is possible to regulate the flow rate by rotating the regulating screw (8 mm hexagonal key) clockwise to decrease

and anticlockwise to increase.

9.3 Repairs

The following diagnostic table indicates the main anomalies which may be encountered, the probable causes and possible solutions.

The anomalies shown are:

- the pump fails to deliver lubricant
- irregular pressure
- irregular flow rate

In case of doubts and/or problems which cannot be resolved do not attempt to disassemble parts of the machine but contact the Engineering Department of DROPSA S.p.A.

10. DISPOSAL

During maintenance or disposal of the machine care should be taken to properly dispose of environmentally sensitive items such as oils or other lubricants. Refer to local regulations in force in your area.

When disposing of this unit, it is important to ensure that the identification label and all the other relative documents are also destroyed.

11. ORDERING INFORMATION

11.1 VERSIONS

Type of motor and R.P.M.*	Adjustable delivery				Max. Press. bar (psi.)	Part No. of Motor Driven Pump 999000 Series Metal Reservoirs Capacity							
	Cm ³ /min		Cu.in./min.			Grease Max. NLGI 2				Oil Viscosity Min. 15 cSt			
	Min.	Max.	Min.	Max.		3Kg. 6.6lbs.	5Kg. 11lb.	10Kg. 22lb.	30Kg. 66lb.	3 Lt.	5 Lt.	10 Lt.	30 Lt.
A.C. 1500 R.P.M.	1,4	8,5	,08	,6	450 (6500)	999234	999214	999224	999204	999244	999264	999274	999254
	2,5	17	,15	1	400 (5800)	999236	999216	999226	999206	999246	999266	999276	999256
	5	33	,30	2	200 (2900)	999232	999212	999222	999202	999242	999262	999272	999252
	Fixed delivery												
A.C. 1500 R.P.M.	8,5		,6		450 (6500)	999334	999314	999324	999304	999344	999364	999374	999354
	17		1		400 (5800)	999336	999316	999326	999306	999346	999366	999376	999356
	33		2		200 (2900)	999332	999312	999322	999302	999342	999362	999372	999352

R.P.M.* and lubricant deliveries indicated in the table refer to 50Hz. motors. With 60Hz. motors speeds and deliveries are increased by 20%.

Complete pumps:

PUMP ASSY. PART NO.	ADJUSTABLE DELIVERY CM ³ /MIN.	PRESSURE BAR	GREASE RESERVOIR KG.	PUMP PART. NO	KIT PART NO.
999525	2,5 ÷ 17	300	30	999206	299462
999510	5,0 ÷ 33	200	5	999212	299474
999527	5,0 ÷ 33	200	10	999222	299474
	Fixed delivery cm ³ /min.				
999506	17	300	30	999306	299462
999533	33	200	10	999322	299474
999540	33	200	30	999302	299474

11.2 Mounting Kit

999 series pumps can be supplied complete with a kit comprising of:

Filling filter– Pressure gauge – Pressure regulating valve and mounting Base.

To order the Kit it is necessary to indicate the pressure of the pump, the number of pump elements and the number of outlets.

Kit Part N°	N° Pump elements	N° outlets	Pressure
299482	1	1	0 ÷ 20 Mpa 0 ÷ 200 bar
299484	2	1	
299486	2	2	
299443	1	1	5 ÷ 35 Mpa 50 ÷ 350 bar
299444	2	1	
299445	2	2	
299481	1	1	5 ÷ 45 Mpa 50 ÷ 450 bar
299483	2	1	
299485	2	2	

12. DIMENSIONS

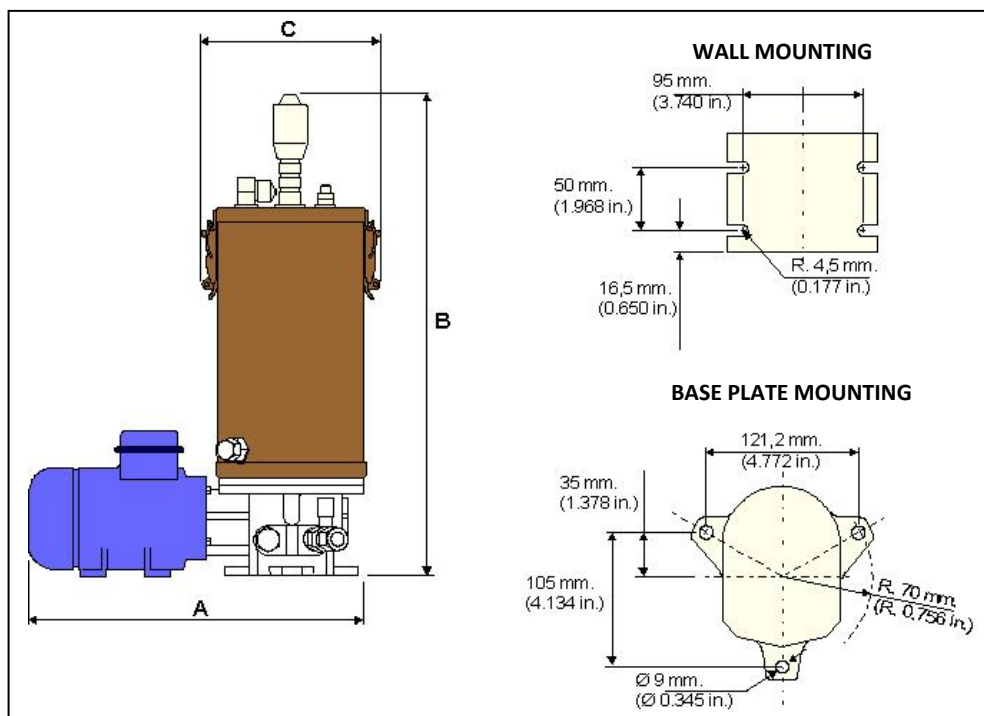

OVERALL DIMENSIONS:

D i m	GREASE RESERVOIR										OIL RESERVOIR									
	3 Kg. (6.6 lbs.)				5 Kg. (11 lbs.)				10 Kg. (22 lbs.)		30 Kg. (66 lbs.)		3 litres (.8 US gal.)		5 litres (1.3 US gal.)		10 litres (2.6 US gal.)		30 litres (8 US gal.)	
	Trans.		Metal		Trans.		Metal		mm.	In.	mm.	In.	mm.	In.	mm.	In.	mm.	In.	mm.	In.
A	300	11.8	300	11.8	300	11.8	300	11.8	423	16.6	453	17.8	300	11.8	300	11.8	423	16.6	453	17.8
B	332	13.0 7	468	18.4	392	15.4	528	20.8	623	24.5	803	31.6	370	14.5	430	16.9	535	21	692	27.2
C Ø	197	7.8	197	7.8	197	7.8	197	7.8	299	11.8	358	14.1	197	7.8	197	7.8	299	11.8	358	14.1

13. HANDLING AND TRANSPORTATION

Prior to shipping, the equipment is carefully packed in cardboard package. During transportation and storage, always maintain the pump the right way up as indicated on the box. On receipt check that package has not been damaged. Then, storage the machine in a dry location.

No particular precautions are required except as noted on the package itself.

Handling must be effected by at least two persons.

- ! Lift the unit with taking account of the right way up indicated on the cardboard carton
- ! The machine components can withstand temperatures, during storage, from -20 to +50°C; however, in order to avoid damage, starting of the machine should occur at a minimum temperature of -5°C.

14. OPERATING HAZARDS



It is necessary to read and understand the possible hazards and risks involved when using centralized lubrication systems. The operator must fully understand the hazards explained in this manual.

An improper use of centralized lubrication systems may cause damages due to an excessive or inadequate lubrication of the points to which it is connected.

It is always necessary to comply with the accident prevention laws and the environmental regulations in force in the area where the centralized lubrication system is used.

Power supply

Any type of intervention must not be carried out before unplugging the machine from power supply. Make sure that no one can start it up again during the intervention.

All the installed electric and electronic equipment, reservoirs and basic components must be grounded.

Flammability

The lubricant generally used in lubrication systems is not normally flammable. However, it is advised to avoid contact with extremely hot substances or naked flames.

Pressure

Prior to any intervention, check the absence of residual pressure in any branch of the lubricant circuit as it may cause oil sprays when disassembling components or fittings.

Noise

Pump does not produce excessive noise, less than 70 dB(A) .

14.1 LUBRICANTS

- It is useful to remember that systems manufactured by **Dropsa SpA** are designed to be used with lubricants with a maximum grade of **NLGI 2**;
- Use only compatible lubricants with **NBR** seals;
- **Dropsa SpA** supplies system lubricated components with **NLGI 2** lubricant.

Family description	NLGI grade	ASTM penetration at +25°C(+77 °F) in 1/10 of mm
Fluid greases	000	445 – 475
Semi-fluid greases	00	400 – 430
Semi-fluid greases	0	355 – 385
Mild greases	1	310 – 340
Medium greases	2	265 - 295

This table provides comparative data between NLGI (National Lubricating Grease Institute) and ASTM (American Society for Testing and Materials) data only for the values concerning systems manufactured by **Dropsa SpA**.

For further information on technical data and safety measures, see **Product Safety Sheet** (Directive **93/112/EEC**) related to the type of lubricant selected or supplied by the manufacturer.

15. PRECAUTIONS

The verification of conformity with the essential safety requirements and regulations of the Machine Directive is effected by means of the compilation of a check list which has been pre-prepared and is contained in the *technical file*.

The lists which are utilised are of three types:

- list of dangers (as in EN 414 referring to EN 292)
- application of essential safety requirements (Machine Dir.)
- electrical safety requirements (EN 60204-1).

The following is a list of dangers which have not been fully eliminated but which are considered acceptable:

- in the version of the pump without a release it is possible to encounter squirts of oil (for this reason appropriate protective clothing must be worn)
- contact with oil -> see the requirements for the use of suitable personal protective clothing
- use of unsuitable lubricant -> the characteristics of the fluid are shown on the pump and in the manual (**in case of doubt contact the Eng. Dept of Dropsa Spa**)
- protection against direct and indirect contact must be provided by the user
- given the purpose of the pump it must always be functioning; for this reason it is necessary to pay attention to the electrical connections which, in the case of a power failure, the customer's machine is restarted only by means of a reset, while the lubrication pump is able to restart automatically.
- incorrect assembly of the regulator (valve) can result in an over pressure which can prejudice the functioning of the pump itself and create danger for the user. This is avoided by stamping the mounting instructions on the table.

INADMISSIBLE FLUIDS	
Fluid	Danger
Lubricants with abrasive additives	High wear rate of contacted parts
Lubricants with silicone based additives	Seizure of the pump
Petrol – solvents – inflammable liquids	Fire – explosion – damage to seals
Corrosive products	Corrosion of the pump– injury to persons
Water	Oxidation of the pump
Food substances	Contamination of the substances themselves

16. WARRANTY INFORMATION

All products manufactured and marketed by Dropsa are warranted to be free of defects in material or workmanship for a period of at least 12 months from date of delivery. Extended warranty coverage applies as follows:

Complete system installation by Dropsa: 24 Months

All other components: 12 months from date of installation; if installed 6 months or more after ship date, warranty shall be maximum of 18 months from ship date.

If a fault develops, notify us giving a complete description of the alleged malfunction. Include the part number(s), test record number where available (format xxxxxx-xxxxxx), date of delivery and installation and operating conditions of subject product(s). We will subsequently review this information and, at our option, supply you with either servicing data or shipping instruction and returned materials authorization (RMA) which will have instructions on how to prepare the product for return. Upon prepaid receipt of subject product to an authorized Dropsa Sales & Service location, we will then either repair or replace such product(s), at our option, and if determined to be a warranted defect, we will perform such necessary product repairs or replace such product(s) at our expense.

Dropsa reserves the right to charge an administration fee if the product(s) returned are found to be not defective.

This limited warranty does not cover any products, damages or injuries resulting from misuse, neglect, normal expected wear, chemically caused corrosion, improper installation or operation contrary to factory recommendation. Nor does it cover equipment that has been modified, tampered with or altered without authorization.

Consumables and perishable products are excluded from this or any other warranty.

No other extended liabilities are stated or implied and this warranty in no event covers incidental or consequential damages, injuries or costs resulting from any such defective product(s).

The use of Dropsa product(s) implies the acceptance of our warranty conditions. Modifications to our standard warranty must be in writing and approved by Dropsa.

17. DECLARATION OF COMPLIANCE WITH CE STANDARDS



Dropsa Spa
 Via Benedetto Croce, 1
 20090 Vimodrone (MI)
 Italy

Tel.: (+39) 02. 250.79.1
 Fax Sales: (+39) 02. 250.79.767
 E-mail: sales@dropsa.it
 Web site: <http://www.dropsa.com>



DICHIARAZIONE CE DI CONFORMITÀ/DECLARATION OF COMPLIANCE WITH STANDARDS/ DECLARATION DE CONFORMITE/ KONFORMITÄTSEKLRÄRUNG DES STANDARDS /DECLARACIÓN DE CONFORMIDAD/ DECLARAÇÃO DE CONFORMIDADE

La società Dropsa S.p.A., con sede legale in Milano, Via Besana,5/ Dropsa S.p.A., registered office in Milan, Via Besana,5 / Dropsa S.p.A. au Siège Social à Milan, Via Besana,5/ Dropsa S.p.A., Sitz in Milano, Via Besana 5/ La sociedad Dropsa S.p.a., con sede legal en Milán, Via Besana,5/ A Dropsa S.p.A, com sede em Milão, via Besana, nº 5

DICHIARA /CERTIFIES / CERTIFIE/ ZERTIFIZIERT, DASS/ DECLARA/ CERTIFICA:

che il prodotto denominato/that the product called/ le produit appellè/ das Produkt mit dem Namen/ el producto que se llama/ o produto chamado:

Descrizione/ Description/ Description/ Beschreibung/ Descripción/ Descrição:	Pompa a pistoni Piston pump
Nome Commerciale/ Product Name/ Dénomination/ Handelsname/ Denominación/ Denominação:	999 series
Versioni/ Versions/ Versions/ Versionen/ Versiones/ Versões:	All versions
Codici/ Codes/ Códigos/:	Serie 999***

è conforme alle condizioni previste dalle Direttive CEE /has been constructed in conformity with the Directives Of The Council Of The European Community on the standardization of the legislations of member states/ a été construite en conformité avec les Directives Du Conseil Des Communautés Europeennes/ Entsprechend den Richtlinien des Rates Der Europäischen Union, für die Standarisierung der Legislative der Mitgliederstaaten, konstruiert wurde/ cumple con las condiciones establecidas por las directivas comunitarias/ foi construído em conformidade com as diretivas do Conselho das Comunidades Europeias:

- 2006/42 CE Direttiva macchine /Machinery Directive/ Directive machines/ Maschinenrichtlinien/Maquinaria / Directiva Máquinas;
- 2006/95 CE Bassa tensione / Low Voltage Directive / Directive Basse Tension/ Niederspannungsrichtlinien/ Directiva de baja tensión/ Directiva de Baixa Tensão;

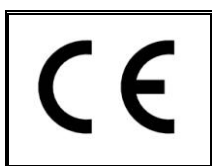

La persona autorizzata a costituire il Fascicolo Tecnico c/presso Dropsa S.P.A.
 The person authorized to compile the Technical File care of Dropsa S.P.A.

Technical Director:
 Maurizio Greco

Legal representative
 Milena Gavazzi

Vimodrone (MI), Gennaio 2012

18. DISTRIBUTORS

 **Dropsa S.p.A.**
Via B. Croce,1
20090 Vimodrone (MI) Italy.
Tel: (+39) 02 - 250.79.1
Fax: (+39) 02 - 250.79.767
E-mail: sales@dropsa.it (Export)
E-mail: vendite@dropsa.it (National)

 **Dropsa (UK) Ltd**
Unit 6, Egham Business Village,
Egham, Surrey, TW20 8RB
Tel: (+44) 01784 - 431177
Fax: (+44) 01784 - 438598
E-mail: salesuk@dropsa.com

 **Dropsa USA Inc.**
6645 Burroughs Ave
48314-2132 Sterling Hts, MI Us -USA
Tel: (+1) 586-566-1540
Fax: (+1) 586-566-1541
E-mail: salesusa@dropsa.com

 **Dropsa GmbH**
Volmerswerther Strasse 80
40221 Dusseldorf 1, Deutschland
Tel: (+49) 0211/39 4011
Fax: (+49) 0211/39 4013
E-mail: sales@dropsa.de

 **Dropsa Ame**
23, Av. des Morillons
Z.I. des Doucettes 91140
Garges Les Gonesse, France
Tel: (+33) 01 39 93 00 33
Fax: (+33) 01 39 86 26 36
E-mail: salesfr@dropsa.com

 **Dropsa do Brazil Ind. E Com. Ltda**
Rua Sobralia 175,
Sao Paulo, Brazil
Tel: (+55) 011-5631-0007
Fax: (+55) 011-5631-9408
E-mail: salesbr@dropsa.com

 **Dropsa Lubrication Systems**
Nr 8 Dongxing Road,
Songjiang Industrial Zone
(Shanghai) Co., Ltd
Tel: +86 (021) 67740275
Fax: +86 (021) 67740205
E-mail: china@dropsa.com

 **Dropsa Australia Pty.**
C20/148 Old Pittwater Road
Brookvale, NSW 2100
Tel: +61 (02) 9938 6644
Fax: +61 (02) 99 386 611
E-mail: salesau@dropsa.com



Web site: <http://www.dropsa.com> - E-mail: sales@dropsa.com